



**NAIMISHA** Corporation

# Meter Seal

PREVENTION. PROTECTION. PEACE OF MIND.

Indicative seal

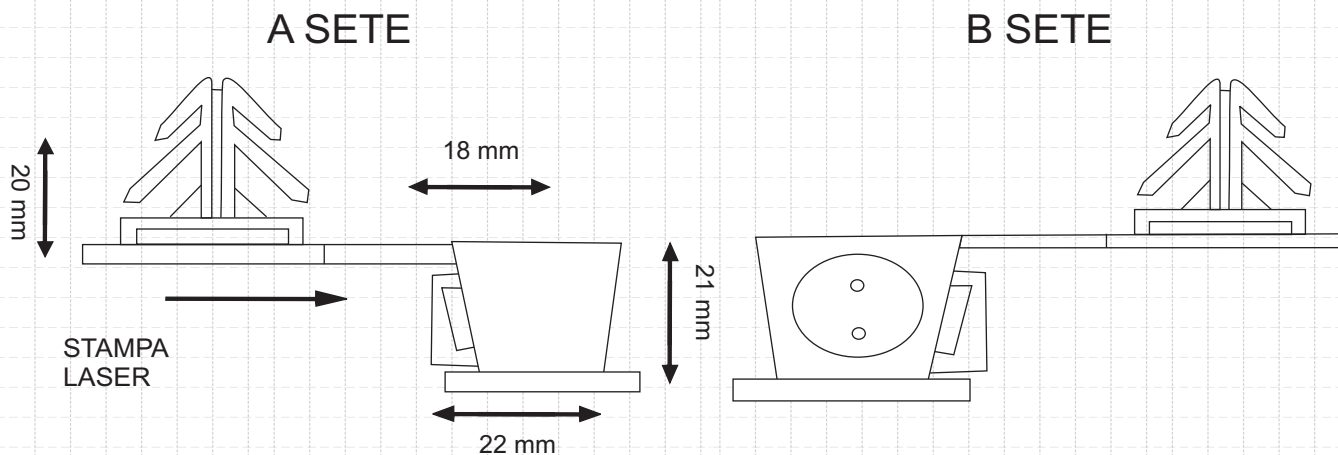

## Technical Data

Material	Tensile Strength (loop)	Numbering	Colours	Customer name/logo	Packing
Housing : PC Wire : SS	Approx : 200N	Foil marked on both body and plunger	Full transparent	Directly Foil marked or embossed	1000 pieces per box

## Product Features and Benefits

- ➔ Transparent body to enable visibility of any tampering.
- ➔ Thin wire of 1.0 mm suitable to enter into small holes.
- ➔ Three Anchor for strong holding of the parts.
- ➔ Serial number laser marked on both body and plunger increase security levels.
- ➔ Wire length can be variable.
- ➔ Close the seal by Finger push.
- ➔ At making it difficult to tamper.
- ➔ Possible to use a strong wire of SS in applications if more strength is required.

## Applications

